

High Performance Cold Air Intake Kit



INSTALLATION INSTRUCTIONS

S&B P/N 75-3030-1

2001-2005

Chevrolet/GMC

Silverado HD/Sierra HD

8.1L

QTY PARTS LIST

- 1 Steel Ring Adapter
- 1 Ring Gasket
- 4 #10-24 Pan Head Screws
- 8 #10 Washers
- 4 #10-24 Nylock Nuts
- 2 3.75" - 2" Adapters
- 1 4" - 2" Adapter
- 1 Intake Box

QTY PARTS LIST

- 1 Intake Tube
- 1 Intake Lid
- 1 CARB Sticker
- 1 Instruction Sheet
- 4 #60 Hose Clamps
- 2 #64 Hose Clamps
- 4 Sealing Washers
- 4 SS Pan Head Screws
- 1 Air Filter

TOOLS REQUIRED

- 10mm Wrench & Socket Wrench
- Phillips Screwdriver
- 5/16" Socket or Nut Driver

1. With engine off, disconnect the negative battery cable. Loosen hose clamp connecting the OEM air intake to the throttle body.



2. Disconnect mass air sensor.



3. Loosen clamp at box.

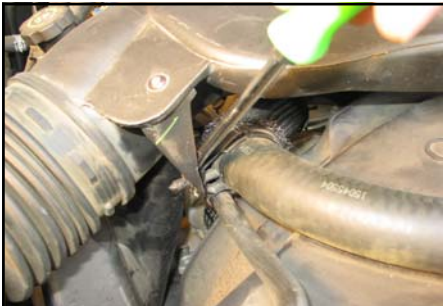

5. Remove OEM air intake tube.



5. Lift and remove OEM air box.



6. Remove and retain the 4 screws (2 long, 2 short) in bottom of air box tray & remove grommets.



7. Assemble filter adaptor to box using hardware provided. Be sure to put gasket between box and adapter.

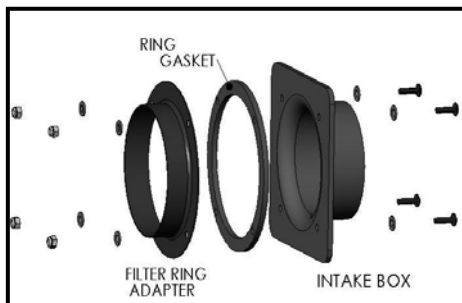

8. Remove mass air sensor from OEM box.



9. Remove flange adapter from mass air



10. Install 3 3/4"x 2" flange adapter onto mass air sensor (leave clamp loose).



11. Set S&B High Performance Air Box in vehicle and secure using 4 (2 long, 2 short) of the screws you retained in Step 7. Do not tighten completely.

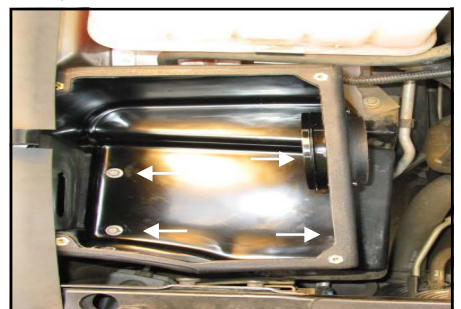

INSTALLATION INSTRUCTIONS (continued)

12. Attach mass air intake to S&B air box and tighten both clamps.



13. Attach 3 3/4" to 2" adapter sleeve



14. Attach 4" x 2" adapter sleeve to S&B air intake tube with #64 hose clamp. NOTE: On some models it may be necessary to trim fan shroud slightly to allow for S&B air intake



15. Install S&B air intake tube and tighten clamps on both ends. Tighten all adapter hose clamps and 4 screws in bottom of box.



16. Reconnect mass air sensor.



17. Install S&B High Performance Filter and tighten clamp.



18. Install the clear intake box lid using the supplied pan head screws and washers.



19. Reconnect negative battery cable and check installation to make sure everything is correct and tight.

Smog Certification Note:

The California Air Resource Board (CARB) requires that an E.O. identification label be applied to the vehicle in order to pass a smog check inspection when a High Performance Intake Kit has been installed.

You must place the E.O. label provided on or near the intake kit after installation so that a smog check technician can easily verify the E.O. number.

PERFORMANCE TESTING

1. Engage parking brake and start your engine. To ensure that the system was installed properly, listen for abnormal noises. If an air leak is detected, re-inspect hoses and connections as they may need to be tightened.
2. S&B FILTERS RECOMMENDS THAT YOU KEEP YOUR OEM INTAKE SYSTEM IN THE EVENT IT IS REQUIRED IN THE FUTURE.
3. In order to maintain proper warranty, all connections and components must be checked periodically for re-alignment and to tighten all connections. Failure to do so will void your warranty.
4. Use only S&B Cleaning and Oil products to service your filter. Using another company's oil and cleaner products may void your warranty.

Call (909) 947-0015 should you have any questions or comments.

787 S. Wanamaker Avenue, Ontario, CA 91761
(909) 947-0015 Phone • (909) 947-0603 Fax
www.sbfilters.com